

KANTHAL® ADDITIVE MANUFACTURING DESIGN GUIDELINE

FOR KANTHAL® AM100

This design guideline serves as a general recommendation when designing for 3D printing of Kanthal® AM100. The results may differ based on actual designs. It is also recommended to consider specific application conditions when designing.

WALL THICKNESS (t)

MAXIMUM: 20 MM

MINIMUM: 0.5 MM (0.2 MM*)

*0.5 mm is recommended for minimum thickness, however it is possible to use 0.2 mm depending on the application.

Larger wall thickness has higher risk of crack formation.

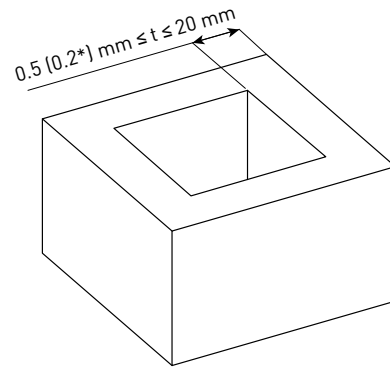
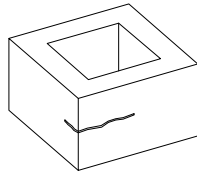

OVERHANG ANGLES

MAXIMUM: 45°

Overhangs larger than 45° will render rough surfaces.

Overhang larger than 45° can be achieved by adding supporting structure, which can later be removed.

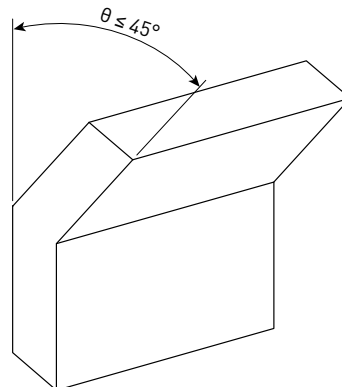
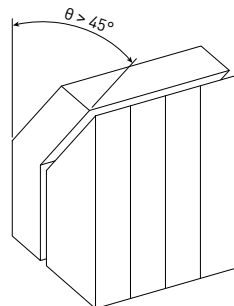
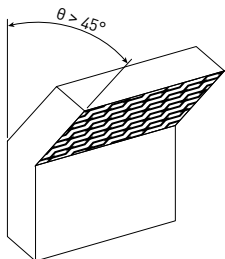

HOLES AND CHANNELS

VERTICAL

MINIMUM DIAMETER: 1 MM (0.4 MM*)

*1 mm is recommended for minimum hole diameter, however it is possible to use 0.4 mm depending on the application.

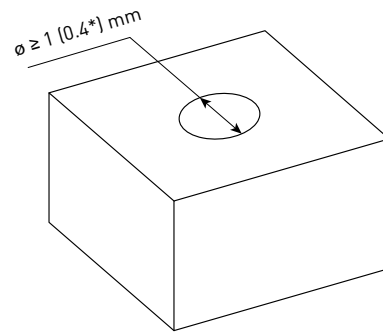

HORIZONTAL

Horizontal holes and channels are not recommended due to the effect of overhang. It is recommended to follow 45° overhang rules. If needed, it is recommended to design cross sections in teardrop or diamond shapes.

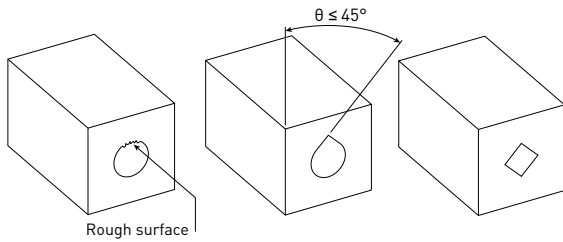

THIN WALL TUBES

MINIMUM WALL THICKNESS: 0.5 MM (0.2 MM*)

*0.5 mm is recommended for minimum thickness, however it is possible to use 0.2 mm depending on the application.

MINIMUM INNER DIAMETER: 1 MM (0.4 MM*)

*1 mm is recommended for minimum hole diameter, however it is possible to use 0.4 mm depending on the application.

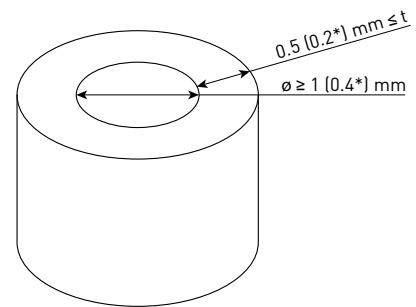

EDGES/CORNERS

AVOID SHARP EDGES IF POSSIBLE

Smooth transition is recommended for better corrosion resistance and lower risk of crack formation.

